

RFID & IoT SPECIFIC TAG SPECIAL COMPANY

# INSIGHT &

[900MHz – ISO18000-6C]

**MEGA-IS-Dragon-W** (Sales Code. C2525-25W)

Special Long Range High Temp. Metal Tag

**insight**  
COMMUNICATION & UBIQUITOUS & SOLUTION



# SPECIAL High-Temp. TAG (MEGA-IS-Dragon-W)

Specialized in RFID Tags , INSIGHT& provides reliable RFID products and satisfactory services to customers from various sectors worldwide.

With strong research and development capabilities and advanced production technology, INSIGHT& commits itself to be the of world's leading provider of RFID products and solution. South Korea, which develop RFID tags and solutions focusing on customer's specific needs.

Rugged RFID tag designed for demanding outdoor environments. Tested for shock, rain, dust, light immunity, oil and chemical resistance, solar tolerance, humidity and extreme temperatures and provides the flexibility to attach to nearly any flat surface. (Mount to metal, Plastic or wood via adhesive or bolts or screws)

(Sales Code. C2525-25W)

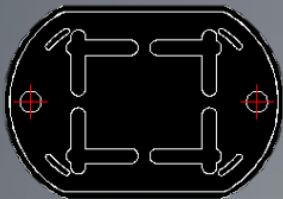
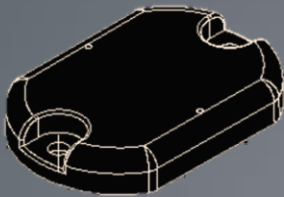

<b>Frequency</b>	▪ UHF : 860 ~ 960MHz
<b>Air Protocol</b>	▪ ISO18000-6C / EPC Class1 Gen2
<b>Operating Country</b>	▪ 860 ~ 960MHz (EU/US/KR/JP)
<b>SIZE</b>	▪ 47(W) x 32(H) x 8(T)mm (3.5mm Bolt Hole)
<b>RFID IC Chip</b>	▪ Alien Higgs3
<b>Memory Configuration</b>	▪ Total Memory : 800bits ▪ EPC : 96bits(Extended up to 488bits) ▪ User : 512bits
<b>Reads Range</b>	▪ ~6m (Hand-held) , ~8m (Fixed) - On Metal
<b>Write &amp;Reading Endurance</b>	Write > 100,000 Cycles / Reading > Infinity
<b>Operating Temperature</b>	▪ -30 ~ 100°C
<b>Storage Temperature</b>	▪ - 45 ~ 270°C
<b>Material</b>	▪ Case : Heat-durable Plastic / Tag : Ceramic
<b>IP Class</b>	▪ IP 64 ( <a href="http://www.dsmt.com/resources/ip-rating-chart/">http://www.dsmt.com/resources/ip-rating-chart/</a> )
<b>Option</b>	▪ EPC Data Extension
<b>Year of Release</b>	▪ 2015

# SPECIAL Long Range METAL TAG

## Case 도면

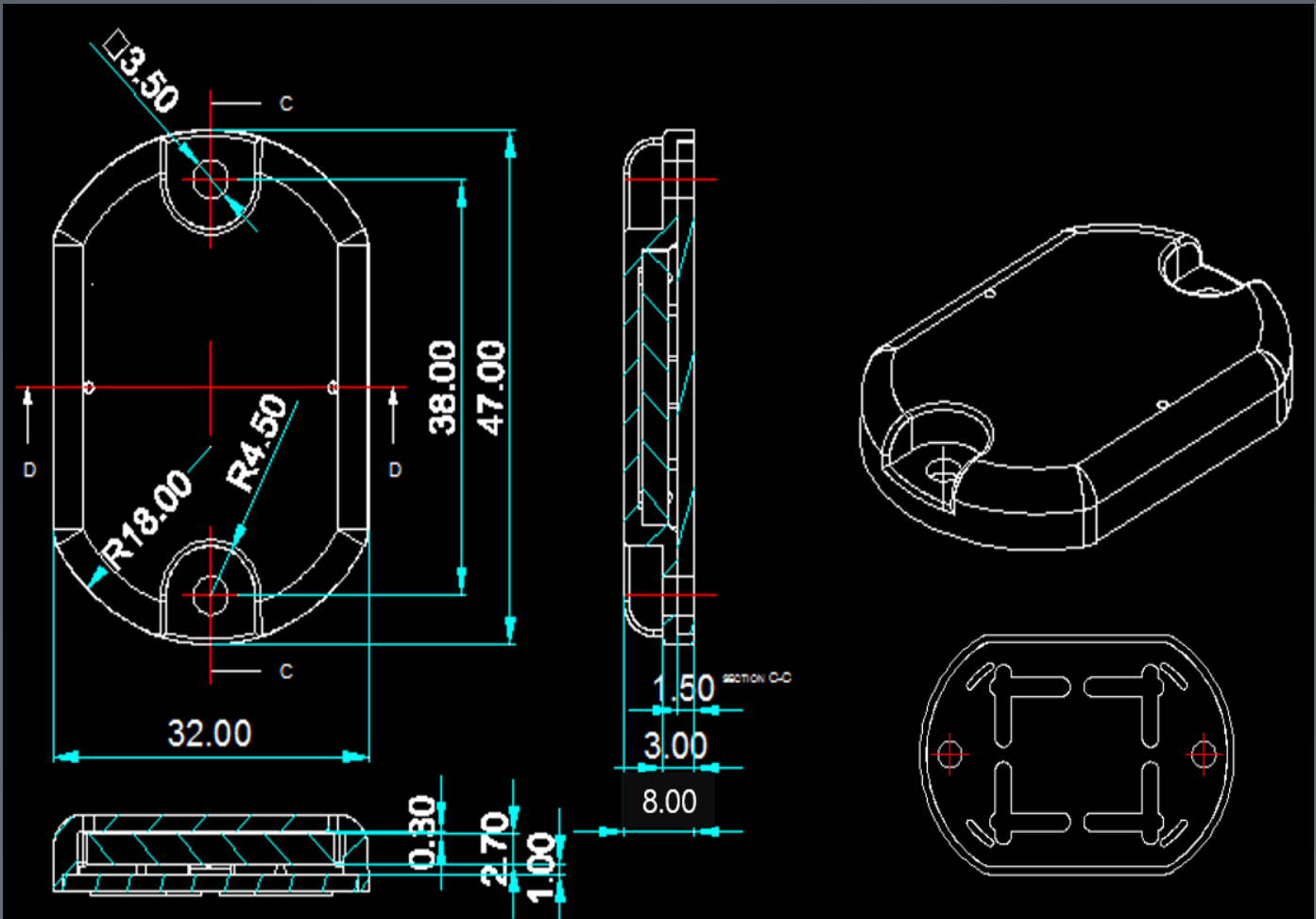

\*\* 발주 시 카드 도면 제공 합니다 \*\*

# 인사이트앤 - 초고온 메탈태그 특허증

## 특허증

CERTIFICATE OF PATENT



**특허** 제 10-1678194 호  
Patent Number

**출원번호** 제 10-2015-0158522 호  
Application Number

**출원일** 2015년 11월 12일  
Filing Date

**등록일** 2016년 11월 15일  
Registration Date

**발명의 명칭** Title of the Invention

고온용 내열성을 갖는 케이스를 구비한 수동형 알에프아이디 태그

**특허권자** Patentee

주식회사 인사이트앤(134111-\*\*\*\*\*)  
서울특별시 금천구 가산디지털1로 165,404호(가산동)

**발명자** Inventor

하경철(660512-\*\*\*\*\*)  
대구광역시 수성구 동원로 123, 201동 102호 (만촌동, 메트로팔레스2단지아파트)

위의 발명은 「특허법」에 따라 특허등록원부에 등록되었음을 증명합니다.

This is to certify that, in accordance with the Patent Act, a patent for the invention has been registered at the Korean Intellectual Property Office.



2016년 11월 15일

**특허청장**

COMMISSIONER,  
KOREAN INTELLECTUAL PROPERTY OFFICE

최 동 규

\*\* 초고온/장거리 태그 국내특허 \*\*

# SPECIAL METAL TAG (MEGA-IS-Dragon-W)

## APPLICATIONS



금형 이력관리



철강자재 이력관리



LPG가스통 이력관리

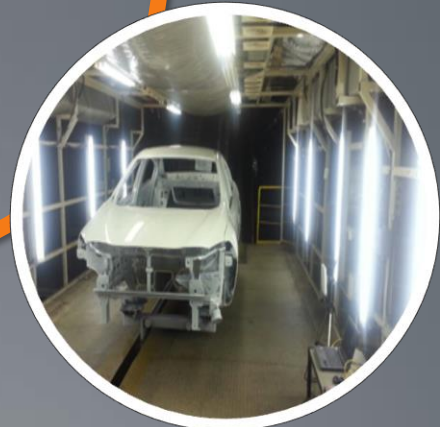

자동차 도장라인 관리



# INSIGHT&

고객과 소통하면서 고객 자산 & 브랜드 보호를 위해 끊임없이 연구합니다.

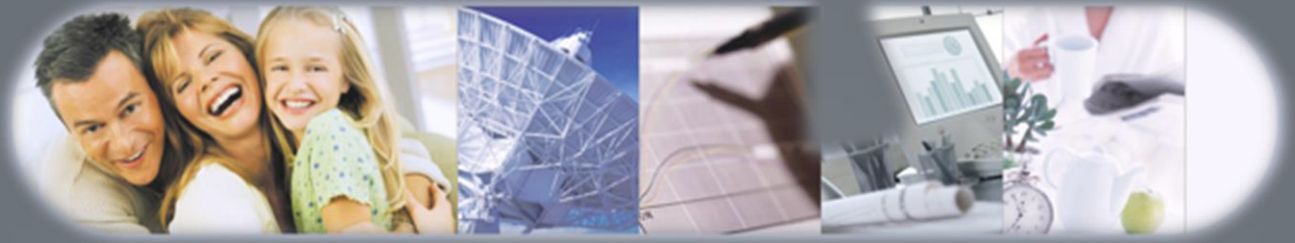

**iNSIGHT**  
COMMUNICATION & UBIQUITOUS & SOLUTION

(주)인사이트앤  
서울 금천구 디지털로 121, 510호(에이스가산타워)  
Tel : 02-2038-2351 / Fax : 0303-3445-7988  
[www.insightn.com](http://www.insightn.com) / Mail : [isall@insightn.com](mailto:isall@insightn.com)

